

CONVEYOR LC

Conveyor
for METAL SHARK® Metal Detectors
product weight max. 6 kg

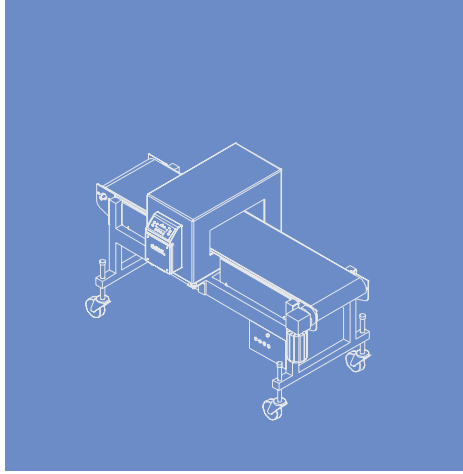

Cassel takes great pride in the engineering and manufacturing of their series LC conveyors to compliment their METAL SHARK® metal detectors.

The conveyor's design has been adapted to the special requirements of metal detectors to provide optimum operation.

Solid Construction

All Cassel conveyors are constructed of high quality Stainless Steel rectangular tubing. All welds are inspected for quality and solid construction.

Hygienic

All welds are ground and polished to provide a clean surface. Welded inserts in the support frame prevent water entry into the frame.

Conveyor Controls

Conveyor Controls are conveniently located in one Stainless Steel enclosure. START, STOP and RESET buttons are located on the enclosure for ease of operation. Optional key reset switches can be provided to allow security of the monitoring of metal detector reset due to company policy of HACCP requirements.

Variable Frequency Drives

Hitachi (220 VAC) or Allen Bradley (110 VAC) are available as optional equipment.



Conveyor system LC

Cassel offers with the LC a conveyor that is special designed for low weight product inspection of max. 6 kg. The LC is installed into an existing production line. The complete system is ready for operation immediately after installation.

The LC conveyor is made of sturdy stainless-steel, appropriate for use in food-industry. They are maintenance-free and constructed for a durable operation in an industrial environment.

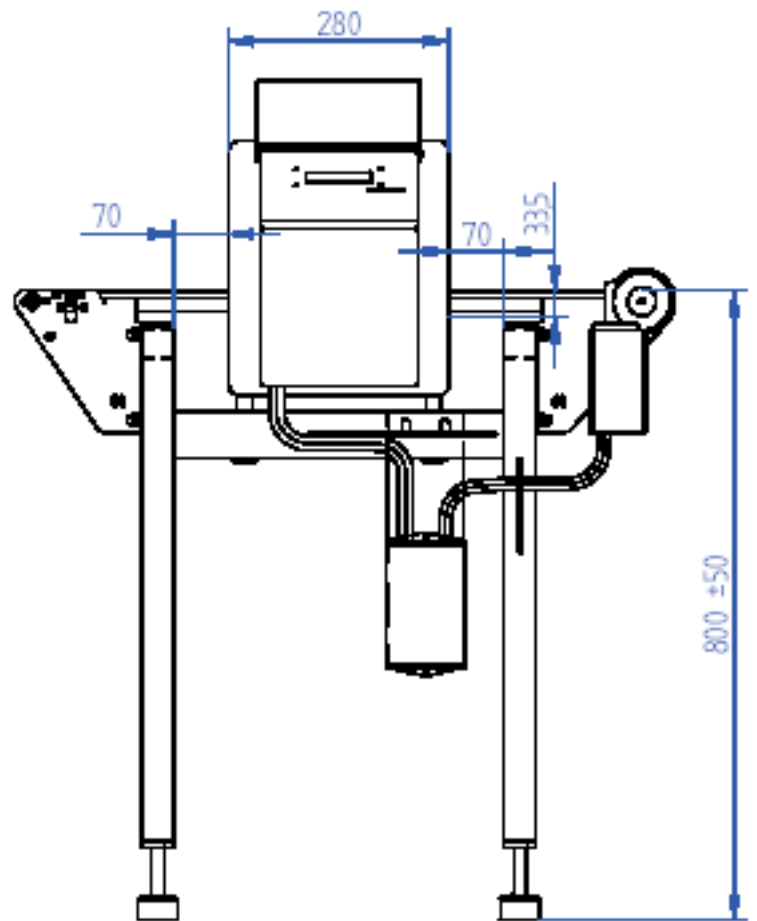

Technical Data

Conveyor length 800 mm (without reject)

Line height 800 mm ± 50mm

Design Stainless steel 304, rectangular tubing, prepared for metal detector METAL SHARK BD assembly, Polyurethan belt white.

Motor Groschopp gear motor drive, 3 Ph, 40W (German high quality brand motor)

Beltspeed 24 m/min.

Belt width 400 mm

Reject Stop on detect, buzzer alarm
Optional: Drop-End conveyor

Product weight max. 6 kg

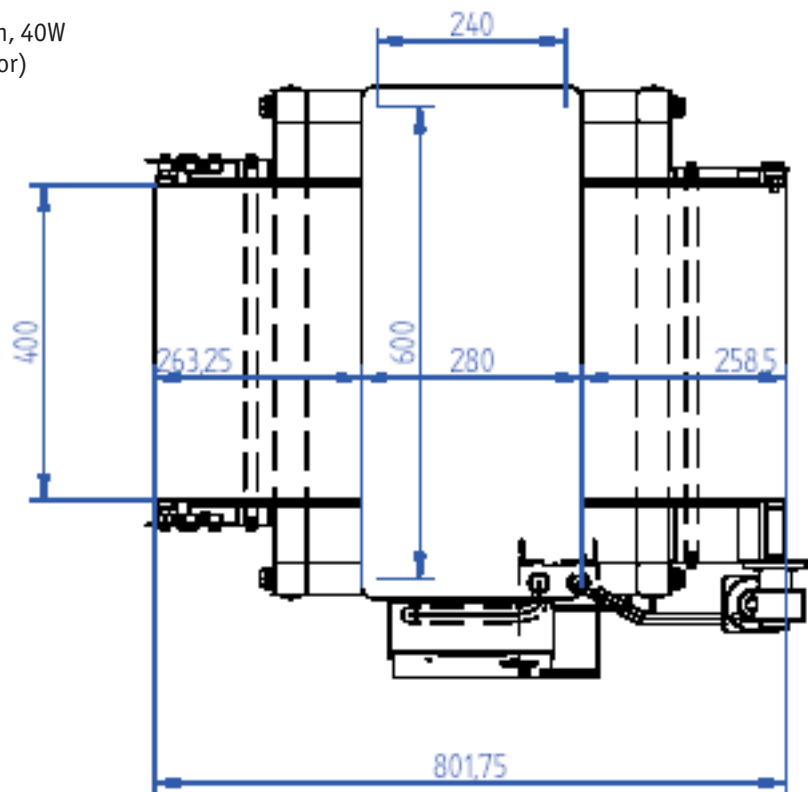

Head quarters:
Cassel Messtechnik GmbH
In der Dehne 10
37127 Dransfeld / Germany
Tel. ++49-5502-91150
Fax ++49-5502-911532
www.cassel.de info@cassel.de

Representation:

CASSEL
METAL SHARK
CE www.cassel.de